

**ASME CLASS 150  
Wafer Type, Flanged Ends, Full Port**

KV-071 (Bracket Mount Type)  
KV-071F (Bracket Mount Type / Fire Safe Type)

**DESIGN FEATURES:**

- **Fire Safe** Design
- Built-in ISO 5211 Mounting Pad for Easy Automation
- Anti-static Devices for Ball-Stem-Body
- Blow-out Proof Stem
- Pressure Balance Hole in Ball Slot
- **TA-LUFT** Design Approved
- Casting Approved by TÜV AD 2000-Merkblatt W0

**APPLICABLE STANDARDS:**

- Design : ASME B16.34
- Fire Safe : API 607 5<sup>th</sup> 2005, ISO 10497
- Wall Thickness : ASME B16.34
- Flanged Ends : ASME B16.5
- Inspection & Testing : API 598, API 6D

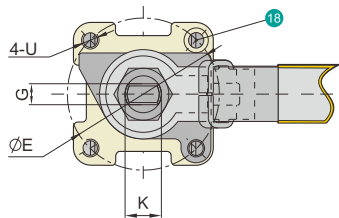
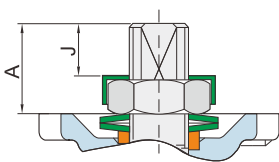

1/2" ~ 3"

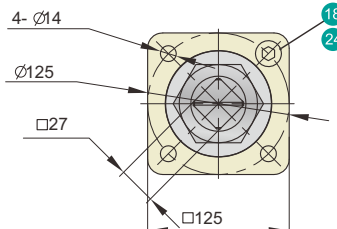

6"

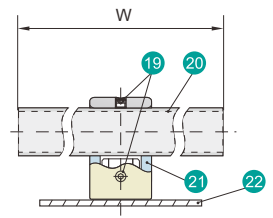

4" ~ 6"

NO.	PART NAME	MATERIALS		
1	Body	CF8M	CF8	WCB
2	End Cap	CF8M	CF8	WCB
3	Ball	CF8M	CF8	
4	Ball Seat	TFM1600 / PTFE / RTFE		
5	Stem	316	304	
6	Anti-Static Device	316	304	
7	Thrust Washer	TFM1600 / PTFE / RTFE		
8	O-Ring	FKM		
9	Stem Packing	PTFE / GRAFOIL*		
10	Bushing	50%SS+ 50%PTFE / 304*		
11	Gland	316		
12	Belleville Washer	301		
13	Stem Nut	A194 - 8		
14	Stop-Lock-Cap	304		
15	Handle (1/2"~3")	304		
16	Handle Sleeve (1/2"~3")	VINYL PLASTIC		
17	Lock Device (1/2"~3")	304		
18	Stop Bolt	A2-70		
19	Set Screw (4"~6")	A193 - B8		
20	Handle (4"~6")	A53+Zn PLATED		
21	Handle Adapter (4"~6")	A351-CF8		
22	Triangle Stopper (4"~6")	304		
23	Body Gasket	PTFE / 316 SPIRAL WOUND + GRAFOIL*		
24	Stop Nut	A2-70		

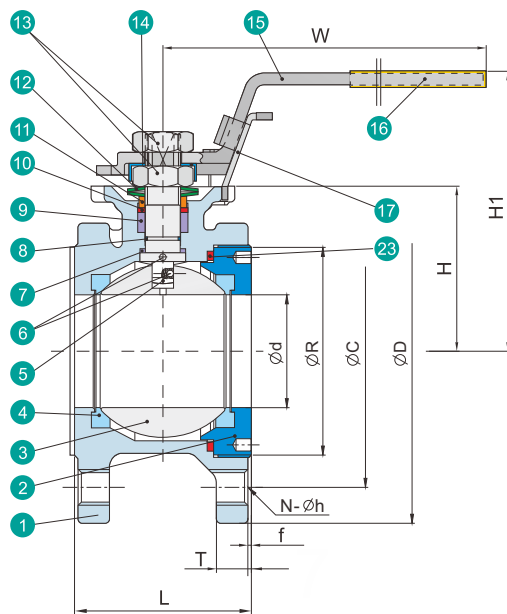

SIZE: DN 15 ~ DN 80

SIZE: DN 100 ~ DN 150

\*Materials for KV-071F (Fire-Safe Models)

**ASME CLASS 150**

**KV-071, KV-071F**

Unit: mm

SIZE	d	L	R	D	C	T	f	H	H1	N	h	W	G	A	J	U	E	K	ISO 5211
1/2"	15.0	42	35.0	90	60.3	8.0	2	41.0	90.5	4	1/2"	135	6.3	17.0	8.1	M5	42	3/8-24UNF	F04
3/4"	20.0	44	43.0	100	69.9	8.9	2	44.0	94.0	4	1/2"	135	6.3	17.0	8.1	M5	42	3/8-24UNF	F04
1"	25.0	50	50.8	110	79.4	9.6	2	46.5	99.0	4	1/2"	170	9.0	22.7	10.2	M6	50	9/16-18UNF	F05
1-1/4"	32.0	60	63.5	115	88.9	11.2	2	55.0	99.0	4	1/2"	170	9.0	24.0	11.0	M6	50	9/16-18UNF	F05
1-1/2"	38.0	65	73.5	125	98.4	12.7	2	64.0	117.0	4	1/2"	200	9.6	25.8	13.9	M8	70	5/8-18UNF	F07
2"	50.0	80	92.0	150	120.7	14.3	2	73.1	124.0	4	5/8"	200	9.6	23.9	13.9	M8	70	5/8-18UNF	F07
2-1/2"	63.5	110	105.0	180	139.7	15.9	2	88.0	148.0	4	5/8"	250	16.0	42.5	24.0	M10	102	7/8-14UNF	F10
3"	76.0	120	127.0	190	152.4	17.5	2	97.0	157.0	4	5/8"	250	16.0	42.6	22.5	M10	102	7/8-14UNF	F10
4"	100.0	150	157.3	230	190.5	22.3	2	117.0	200.0	8	5/8"	280	18.0	51.4	24.5	M10	102	11/8-12UNF	F10
5"	125.0	195	186.0	255	215.9	22.3	2	155.0	270.0	8	3/4"	600	18.0	76.5	36.0	M12	125	13/4-12UNF	F12
6"	150.0	225	215.9	280	241.3	23.9	2	194.0	310.5	8	3/4"	800	18.0	76.5	36.0	M12	125	13/4-12UNF	F12